

5SNG 0600R120590**LoPak phase leg IGBT module**

- $V_{CE} = 1200\text{ V}$
- $I_C = 600\text{ A} \times 2$
- Press-fit pins for reliable auxiliary contacts
- Ultra low-loss rugged Trench IGBT chipset
- NTC thermistor for temperature sensing
- Cu baseplate for low thermal resistance
- Pre-Applied Thermal Interface Material (TIM) to improve thermal conductivity between module and heat sink
- Industry standard package

Maximum rated values

Parameter	Symbol	Conditions	Min.	Max.	Unit
Collector-emitter voltage	V_{ces}	$V_{GE} = 0\text{ V}$, $T_{vj} \geq 25\text{ °C}$		1200	V
DC collector current	I_c	$T_c = 125\text{ °C}$, $T_{vj} = 175\text{ °C}$		600	A
Peak collector current	I_{cm}	$t_p = 1\text{ ms}$		1200	A
Gate-emitter voltage	V_{ges}		-20	20	V
DC forward current	I_f			600	A
Peak forward current	I_{fpm}	$t_p = 1\text{ ms}$		1200	A
Surge current	I_{fsm}			TBD	A
IGBT short circuit SOA	t_{psc}	$V_{GE} \leq 15\text{ V}$, $V_{CC} = 900\text{ V}$ $V_{CE,max} \leq 1200\text{ V}$, $T_{vj} = 175\text{ °C}$		8	us
Isolation voltage	V_{isol}	1 min, $f = 50\text{ Hz}$		4000	V
Max Junction temperature	T_{vj}		-40	175	C
Junction operating temperature	$T_{vj(op)}$		-40	175	C
Case temperature	T_c		-40	125/150	C
Storage temperature	T_{stg}		-40	125	C
Mounting torques	M_s, M_{t1}	Base-heatsink, M5 screws or Main terminals, M6 screws	3	6	Nm

IGBT characteristic values

Parameter	Symbol	Conditions	Min.	Typ.	Max.	Unit
Collector-emitter breakdown voltage	$V_{(BR)CES}$	$V_{GE} = 0 \text{ V}$, $I_C = 3 \text{ mA}$	$T_{vj}=25 \text{ }^\circ\text{C}$	1200		V
Collector-emitter saturation voltage	$V_{CE \text{ sat}}$	$I_C = 600 \text{ A}$, $V_{GE} = 15 \text{ V}$	$T_{vj}=25 \text{ }^\circ\text{C}$		1.55	V
			$T_{vj}=125 \text{ }^\circ\text{C}$		1.7	V
			$T_{vj}=175 \text{ }^\circ\text{C}$		1.8	V
Collector cut-off current	I_{CES}	$V_{CE} = 1200 \text{ V}$, $V_{GE} = -15 \text{ V}$	$T_{vj}=25 \text{ }^\circ\text{C}$		0.1	mA
			$T_{vj}=125 \text{ }^\circ\text{C}$		2	mA
			$T_{vj}=175 \text{ }^\circ\text{C}$		9	mA
Gate leakage current	I_{GES}	$V_{CE} = 0 \text{ V}$, $V_{GE} = \pm 20 \text{ V}$		-150	150	nA
Gate-emitter threshold voltage	$V_{GE(th)}$	$I_C = 24 \text{ mA}$, $V_{CE} = V_{GE}$	$T_{vj}=25 \text{ }^\circ\text{C}$	5.5		V
Gate charge	Q_G				TBD	μC
Input capacitance	C_{ies}				TBD	nF
Internal gate resistance	$R_{g,int}$				2	Ohms
Turn-on delay time	$t_{d(on)}$	$I_C = 600 \text{ A}$, $V_{CE} = 600 \text{ V}$, $V_{GE} = \pm 15 \text{ V}$, $R_{G,on} = \text{TBD}$	$T_{vj}=25 \text{ }^\circ\text{C}$		475	ns
			$T_{vj}=125 \text{ }^\circ\text{C}$		500	ns
			$T_{vj}=175 \text{ }^\circ\text{C}$		550	ns
Rise time	t_r		$T_{vj}=25 \text{ }^\circ\text{C}$		140	ns
			$T_{vj}=125 \text{ }^\circ\text{C}$		175	ns
			$T_{vj}=175 \text{ }^\circ\text{C}$		200	ns
Turn-off delay time	$t_{d(off)}$	$T_{vj}=25 \text{ }^\circ\text{C}$		525	ns	
		$T_{vj}=125 \text{ }^\circ\text{C}$		615	ns	
		$T_{vj}=175 \text{ }^\circ\text{C}$		650	ns	
Fall time	t_f	$I_C = 600 \text{ A}$, $V_{CE} = 600 \text{ V}$, $V_{GE} = \pm 15 \text{ V}$, $R_{G,off} = \text{TBD}$	$T_{vj}=25 \text{ }^\circ\text{C}$		140	ns
			$T_{vj}=125 \text{ }^\circ\text{C}$		170	ns
			$T_{vj}=175 \text{ }^\circ\text{C}$		180	ns
			Turn-on switching energy	E_{on}	$I_C = 600 \text{ A}$, $V_{CE} = 600 \text{ V}$, $V_{GE} = \pm 15 \text{ V}$, $L_s = 35 \text{ nH}$, $R_{g,on} = \text{TBD}$	$T_{vj}=25 \text{ }^\circ\text{C}$
$T_{vj}=125 \text{ }^\circ\text{C}$		156				mJ
$T_{vj}=175 \text{ }^\circ\text{C}$		182				mJ
Turn-off switching energy	E_{off}	$I_C = 900 \text{ A}$, $V_{CE} = 600 \text{ V}$, $V_{GE} = \pm 15 \text{ V}$, $L_s = 35 \text{ nH}$	$T_{vj}=25 \text{ }^\circ\text{C}$		88	mJ
			$T_{vj}=125 \text{ }^\circ\text{C}$		110	mJ
			$T_{vj}=175 \text{ }^\circ\text{C}$		124	mJ
Short circuit current	I_{SC}	$V_{GE} = 15 \text{ V}$, $V_{CC} = 900 \text{ V}$, $V_{CEM \text{ CHIP}} \leq 1200 \text{ V}$	$T_{vj}=175 \text{ }^\circ\text{C}$		2500	A

Diode characteristic values

Parameter	Symbol	Conditions	Min.	Typ.	Max.	Unit
Forward voltage	V_F	$I_F = 600 \text{ A}$	$T_{vj} = 25 \text{ }^\circ\text{C}$		1.65	V
			$T_{vj} = 125 \text{ }^\circ\text{C}$		1.7	V
			$T_{vj} = 175 \text{ }^\circ\text{C}$		1.8	V
Peak reverse recovery current	I_{rm}	$I_F = 600 \text{ A}$ $V_{CE} = 600 \text{ V}$ $V_{GE} = \pm 15 \text{ V}$ $L_s = 35 \text{ nH}$ $R_{g,on} = \text{TBD}$	$T_{vj} = 25 \text{ }^\circ\text{C}$		330	A
			$T_{vj} = 125 \text{ }^\circ\text{C}$		355	A
			$T_{vj} = 175 \text{ }^\circ\text{C}$		365	A
Recovered charge	Q_{rr}	$I_F = 600 \text{ A}$ $V_{CE} = 600 \text{ V}$ $V_{GE} = \pm 15 \text{ V}$ $L_s = 35 \text{ nH}$ $R_{g,on} = \text{TBD}$	$T_{vj} = 25 \text{ }^\circ\text{C}$		50	μC
			$T_{vj} = 125 \text{ }^\circ\text{C}$		90	μC
			$T_{vj} = 175 \text{ }^\circ\text{C}$		197	μC
Reverse recovery time	t_{rr}	$I_F = 600 \text{ A}$ $V_{CE} = 600 \text{ V}$ $V_{GE} = \pm 15 \text{ V}$ $L_s = 35 \text{ nH}$ $R_{g,on} = \text{TBD}$	$T_{vj} = 25 \text{ }^\circ\text{C}$		367	ns
			$T_{vj} = 125 \text{ }^\circ\text{C}$		762	ns
			$T_{vj} = 175 \text{ }^\circ\text{C}$		800	ns
Reverse recovery energy	E_{rec}	$I_F = 600 \text{ A}$ $V_{CE} = 600 \text{ V}$ $V_{GE} = \pm 15 \text{ V}$ $L_s = 35 \text{ nH}$ $R_{g,on} = \text{TBD}$	$T_{vj} = 25 \text{ }^\circ\text{C}$		14	mJ
			$T_{vj} = 125 \text{ }^\circ\text{C}$		31	mJ
			$T_{vj} = 175 \text{ }^\circ\text{C}$		37	mJ

NTC Thermistor

Parameter	Symbol	Conditions	Min.	Typ.	Max.	Unit
Rated resistance	R_{25}	$T_c = 25 \text{ }^\circ\text{C}$		5		K-ohms
R100	R_{100}	$T_c = 100 \text{ }^\circ\text{C}$	468		517	ohms
B-value	$B_{25/50}$	$R_{25} = R_{25} \exp [B_{25/50}(1/T_2 - 1/(298.15\text{K}))]$		3375		K
B-value	$B_{25/100}$	$R_{25} = R_{25} \exp [B_{25/100}(1/T_2 - 1/(298.15\text{K}))]$		3433		K

Package properties

Parameter	Symbol	Conditions	Min.	Typ.	Max.	Unit
IGBT thermal resistance junction to case	$R_{th(j-c)} \text{ IGBT}$	per switch			0.043	K/W
Diode thermal resistance junction to case	$R_{th(j-c)} \text{ DIODE}$	per switch			0.095	K/W
IGBT thermal resistance case to heatsink	$R_{th(c-s)} \text{ IGBT}$	IGBT per switch, $I_{TIM} = 5 \text{ W/m} \times \text{K}$		0.03		K/W
Diode thermal resistance case to heatsink	$R_{th(c-s)} \text{ DIODE}$	Diode per switch, $I_{TIM} = 5 \text{ W/m} \times \text{K}$		0.04		K/W
Comparative tracking index	CTI					
Module stray inductance	$L \sigma \text{ CE}$	per switch		20		nH
Resistance, terminal-chip	RCC'+EE'	per switch	$T_{vj} = 25 \text{ }^\circ\text{C}$	0.95		m-ohms
			$T_{vj} = 125 \text{ }^\circ\text{C}$	1.35		
			$T_{vj} = 175 \text{ }^\circ\text{C}$	1.55		K/W

Mechanical properties

Parameter	Symbol	Conditions	Min.	Typ.	Max.	Unit
Dimensions	L x W x H	Typical	152 x 62 x 17			
Clearancedistance in air	d_a	According to IEC 60664-1 and EN 50124-1	Term. to base:	12.5		mm
			Term. to base:	10		
Surface creepage distance	d_s		Term. to base:	14.5		
			Term. to base:	13		
Mass	m			350		g

Electrical configuration

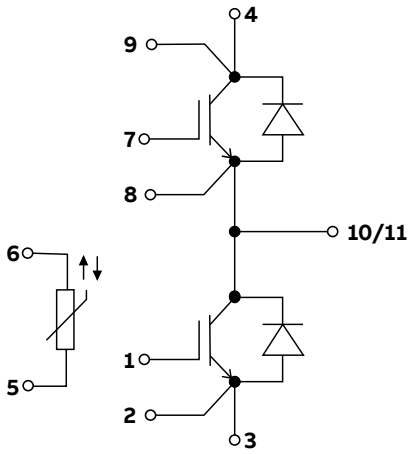

Outline drawing (mm)

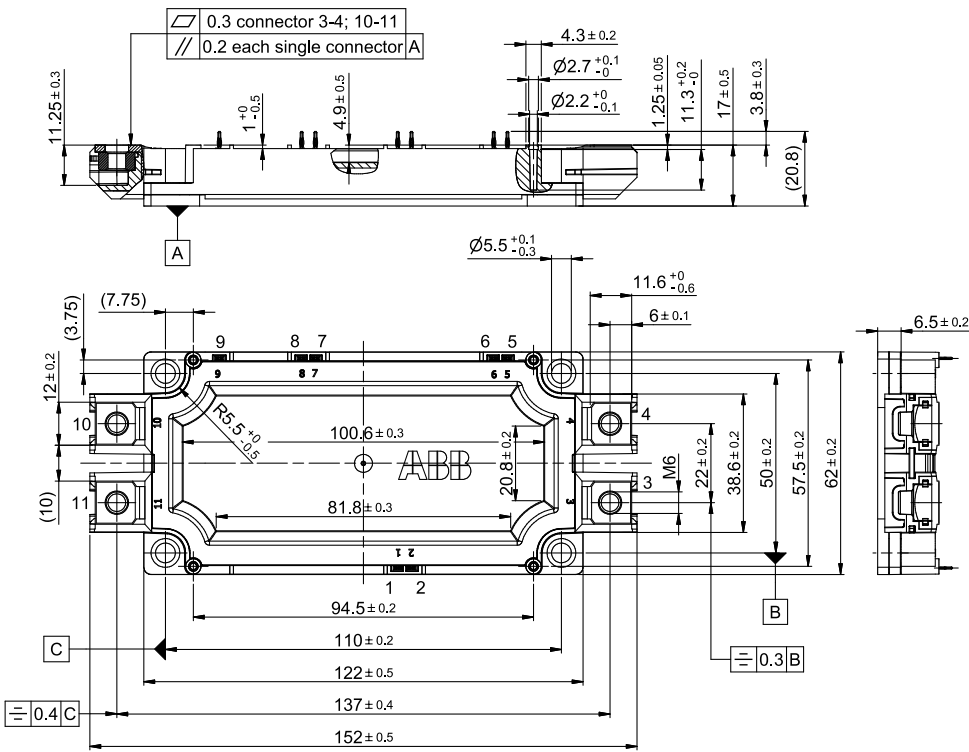

PCB drill hole pattern for press-fit

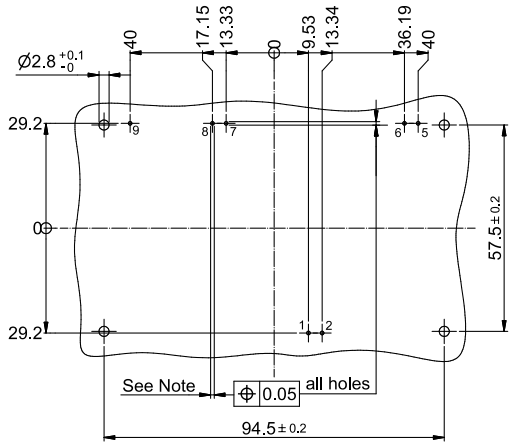

Note:
 Ø1^{+0.09}_{-0.06} Diameter of finished plated through-hole
 Ø1.15 Diameter of drilled hole

Note: For detailed mounting instructions refer to ABB Document No. 5SYA 2113.

Fig. 1 Typical on-state characteristics, chip level

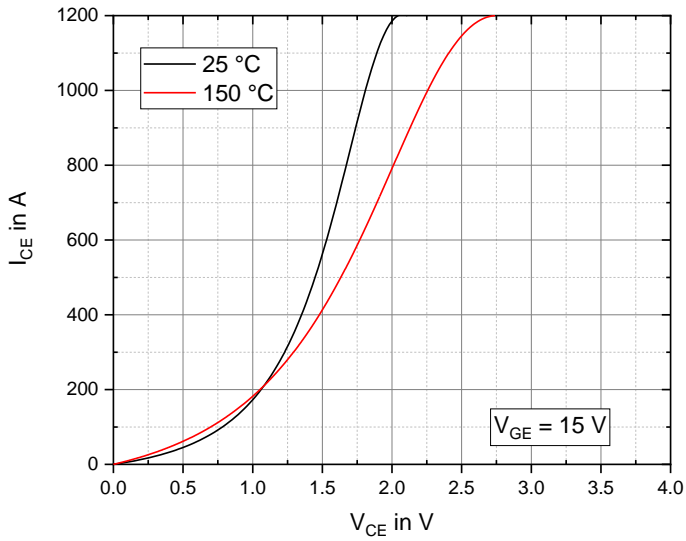

Fig. 2 Typical transfer characteristics, chip level

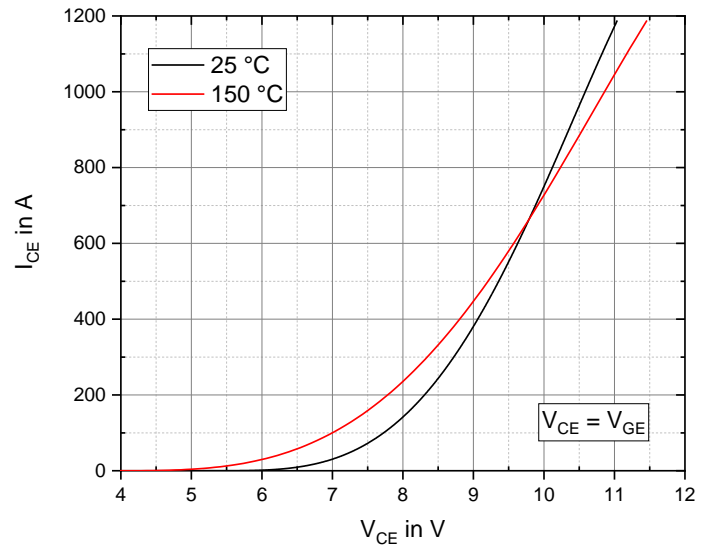

Fig. 3 Typical diode forward characteristics, chip level

